

# HEATER TANK LIFT TRUCK - A-LIFT-HTL-27-300-44

\*\*\*ANY ADDITIONS, DELETIONS, OR OMISSIONS MUST BE CORRECTED ON THIS DRAWING AS THIS DRAWING WILL BE CONSIDERED ALL INCLUSIVE\*\*\*

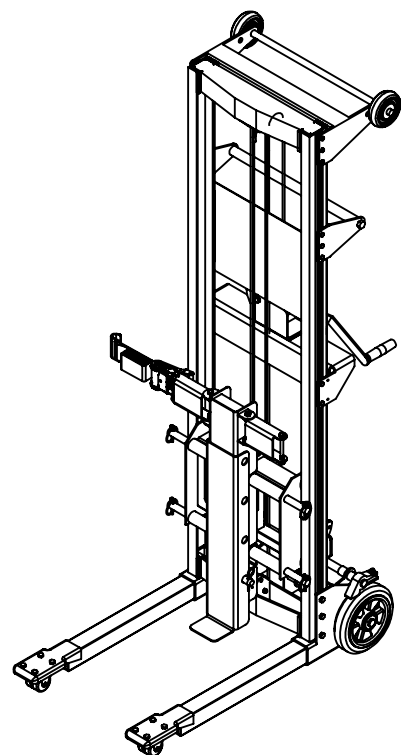
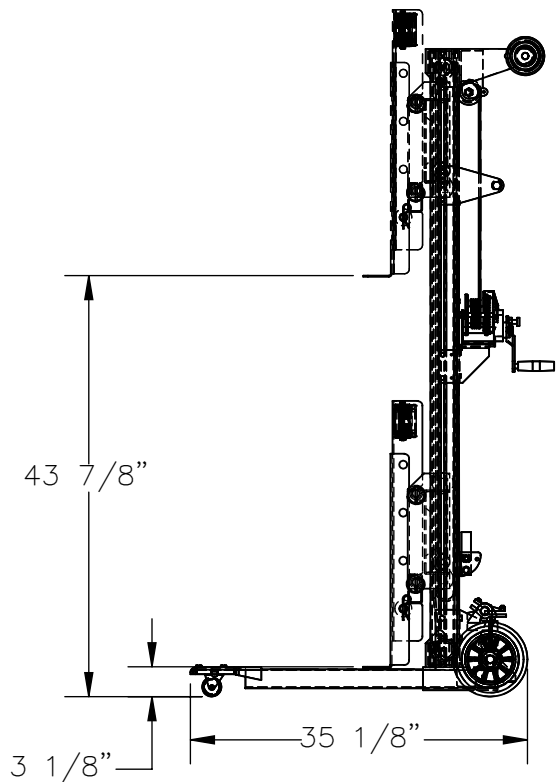
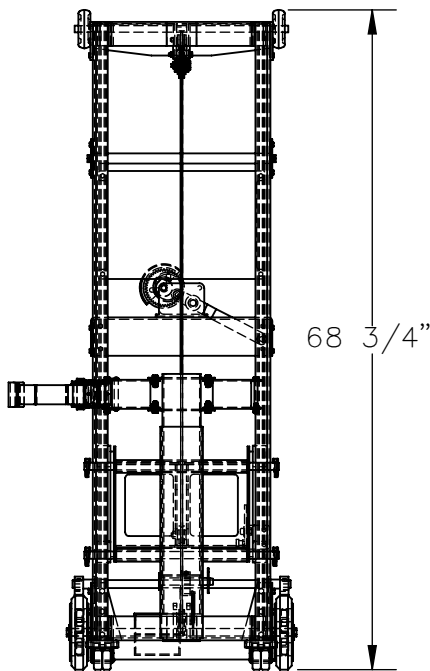
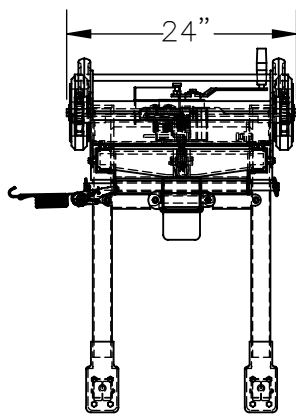

\*\*\*ANY ADDITIONS, DELETIONS, OR OMISSIONS MUST BE CORRECTED ON THIS DRAWING AS THIS DRAWING WILL BE CONSIDERED ALL INCLUSIVE\*\*\*  
 ALL GRAPHICS PROVIDED ARE FOR REFERENCE ONLY. IF CERTAIN DIMENSIONS ARE CRITICAL PLEASE VERIFY THOSE DIMENSIONS WITH YOUR SALESPERSON

DIMENSION TOLERANCE ±1/2"

## STANDARD FEATURES

- MODEL NUMBER IS A-LIFT-HTL-27-300-44
- DURABLE STEEL & ALUMINUM CONSTRUCTION
- CAPACITY IS: 300 LBS.
- OVERALL WIDTH IS: 24"
- OVERALL LENGTH IS: 35 1/8"
- OVERALL HEIGHT IS: 68 3/4"
- MAX DIAMETER OF TANK IS: 27" (NOT SHOWN)
- TANK LOWERED HEIGHT IS: 3 1/8"
- TANK MAX RAISED HEIGHT : 43 7/8"
- QTY (1) RATCHET STRAP INCLUDED TO SECURE HEATER TANK TO LIFT ATTACHMENT
- HEATER TANK ATTACHMENT IS TOUGH BAKED IN POWDER COAT YELLOW FINISH
- APPROXIMATE WEIGHT IS 136 LBS

## SPECIAL FEATURES

- NONE

<b>A P P R O V A L</b>	I, THE UNDERSIGNED, AGREE THAT THE PRODUCT AS REPRESENTED SATISFIES DESIGN AND DIMENSION REQUIREMENTS. I ALSO ACKNOWLEDGE MY DUTY TO CONFIRM PRODUCT AND INSTALLATION COMPLIANCE WITH ALL APPLICABLE FEDERAL, STATE AND LOCAL REGULATIONS AND STANDARDS. <b>UNITS REQUIRING APPROVAL DRAWINGS OR MODIFIED ARE NON-RETURNABLE</b> [ ] As drawn      [ ] As marked
	Signed: _____ Date: _____ Printed Name: _____
	LEAD TIME WILL START UPON RECEIPT OF SIGNED APPROVAL DRAWING

DISTRIBUTOR'S NAME:		P.O.#
<b>VESTIL MANUFACTURING</b>		X
DRAWN BY: JGP		W.O.#
DATE: 7/8/2020		X
REFERENCE: X		SALES: X
SCALE: 1:20		FILE NAME:
QUOTED LEAD TIME: X		21-007-153
QUOTE #		X